

ALL IN ONE

System solution for management of building air conditioning

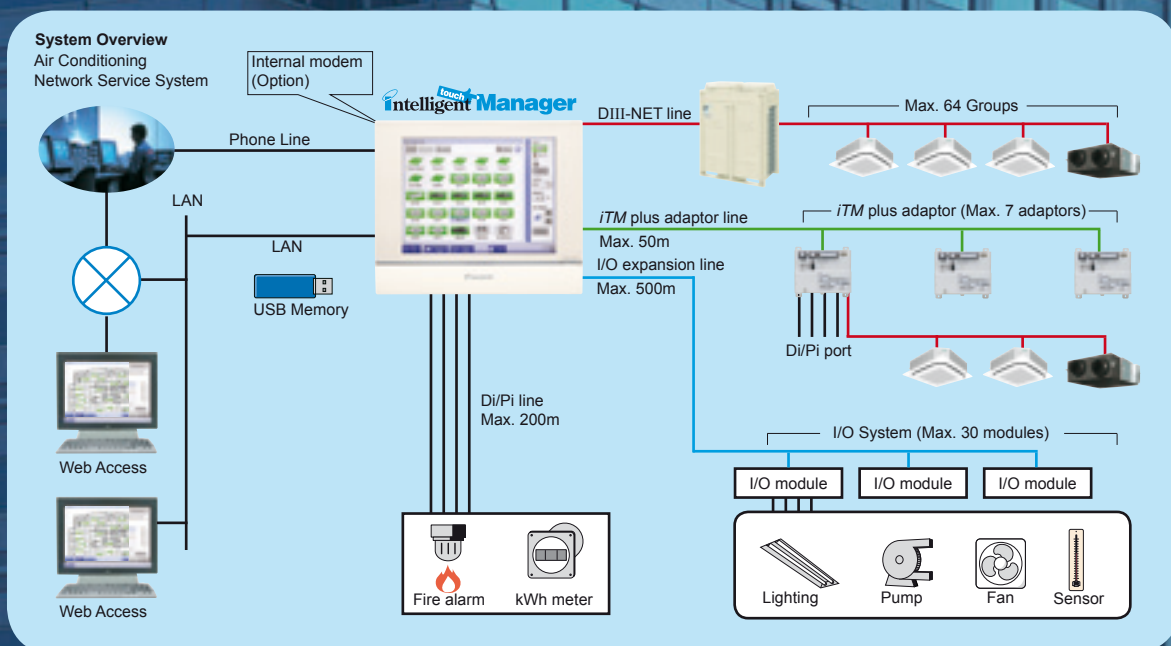

State-of-the-art management of building air conditioning



One touch selection to total air comfort

Daikin proudly introduces its new *intelligent Touch Manager*, a VRV system controller featuring an array of simple, useful system management functions for added value.

Central control

- Handy area settings simplify detailed management of VRV.
- Display of floor plans enables a quick search of desired air conditioning units.
- Operation history shows manner of control and origin in past operations of air conditioning units.



P.03

Remote Access

- Remote access with a PC allows total air conditioning management using the same type of screens as those displayed in the intelligent Touch Manager.
- Authorised users can centrally control individual air conditioning units from their own computers.

P.04

Automatic Control

- VRVs are controlled automatically throughout the year by the schedule function.
- Interlocking VRVs and other equipment enables easy automation of building facilities operation.
- Setback adjusts temperature settings even when rooms are unoccupied.

P.05

Energy Management

- The Energy Navigator feature simplifies energy management by tracking energy consumption data and identifying inefficient operation.



P.07

Troubleshooting

- Contact information of maintenance contractors can be registered and displayed.
- E-mails are sent automatically to alert of malfunctions and potential trouble.
- The *intelligent Touch Manager* can link to the Air Conditioning Network Service System for 24-hour monitoring of operating conditions and status.

P.09

Scalability

- A single *intelligent Touch Manager* can manage a small building or be expanded to handle medium- to large-sized buildings.
- Large building properties can also take advantage of the *iTM integrator* to link up and expand system up to five *intelligent Touch Managers* for integrated monitoring.

P.10

Central control

Simple operation

Using the easily recognised icons and intuitive menu screens, even novice users can operate and monitor the system like an expert.



List view

Designed for simplicity, this menu provides a quick view of overall status and essential information in a list format. Using the sorting function, air conditioning units operating under the same conditions and status are identified for comparison and assessment.

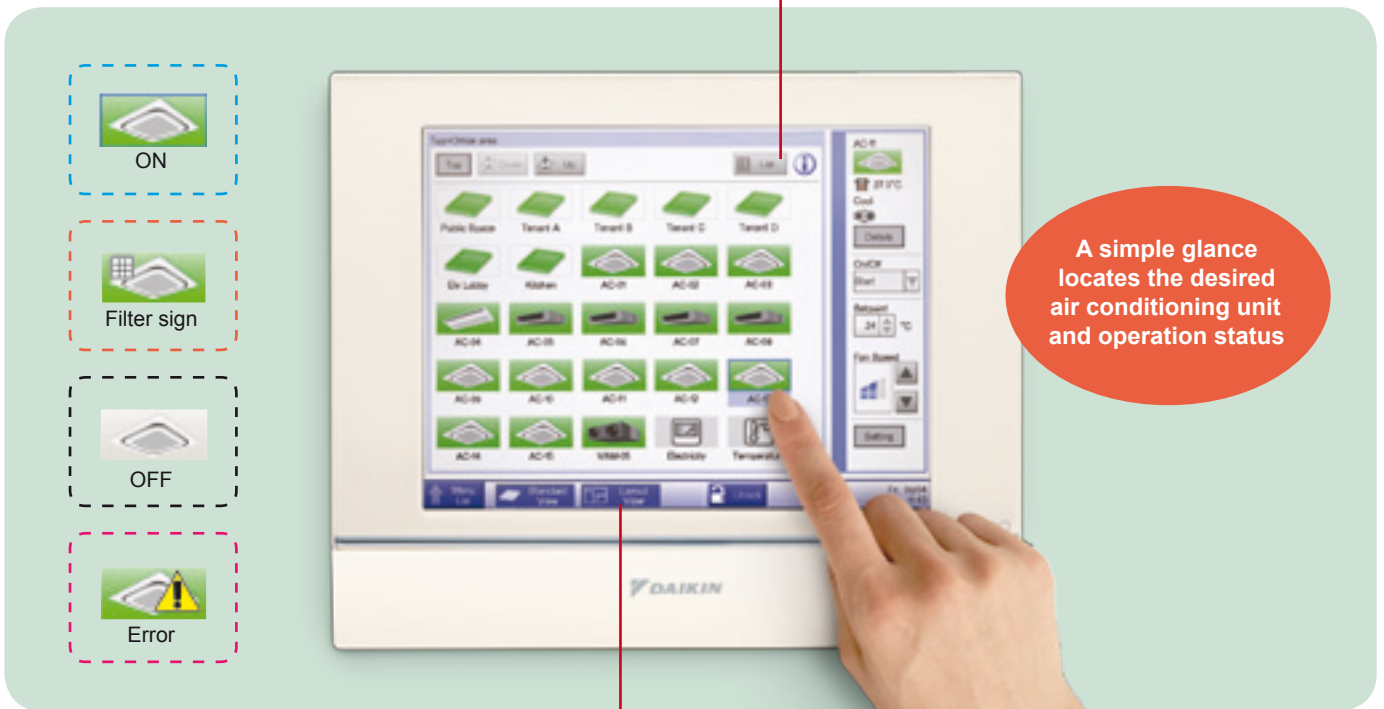

Layout view

A special feature utilises building floor plans to provide a visual representation of system equipment. Without having to memorise equipment names, users can visually locate any installed equipment by searching its position on the floor plan.

Language can be changed according to user needs.

Comprehensive management history

Rather than simply recording malfunctions, the *intelligent Touch Manager* provides a comprehensive history for equipment events including operation, status change, automatic control, and settings. This assists in system optimisation for additional energy savings and comfort as well as for preventive maintenance.

Easy access to a wide range of menus

Users can readily access their desired menu screens simply by touching the menu icon from the main screen.



Automatic Control



System settings

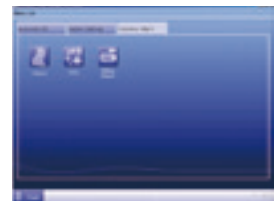

Operation management

Remote Access

Air conditioning control using a PC

Air conditioning units in buildings can be operated via PC.

Authorised users can operate building air conditioning equipment with a PC and have the same type of screens displayed as those displayed in the *intelligent Touch Manager*.

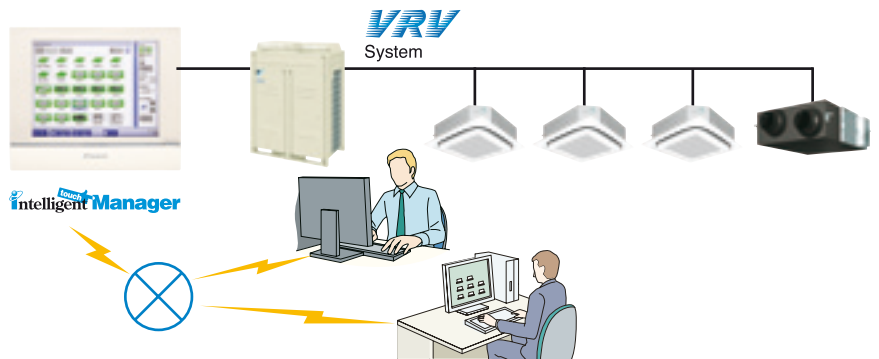

Air conditioning units in buildings at distant locations can also be remotely monitored and controlled.

Operating air conditioning equipment using a computer is comparable to that of the *intelligent Touch Manager*. Administrator can centrally operate and monitor individual units and systems at distant locations as if they were working in the same building.

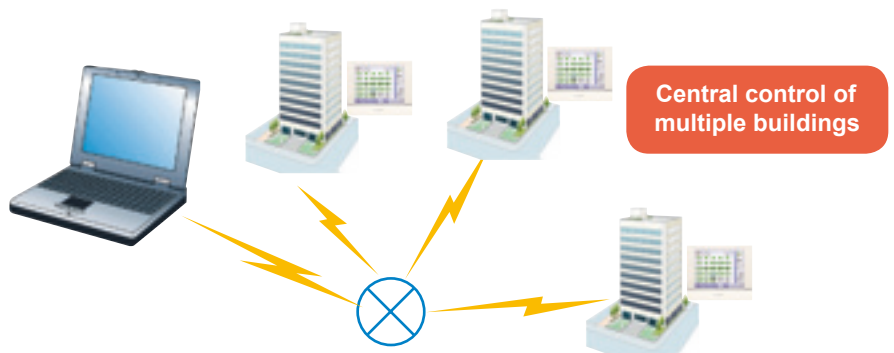

Automatic control

Automatic operation for the entire year

Calendar settings can automate daily management of air conditioning equipment for the entire year to optimise energy savings and comfort.

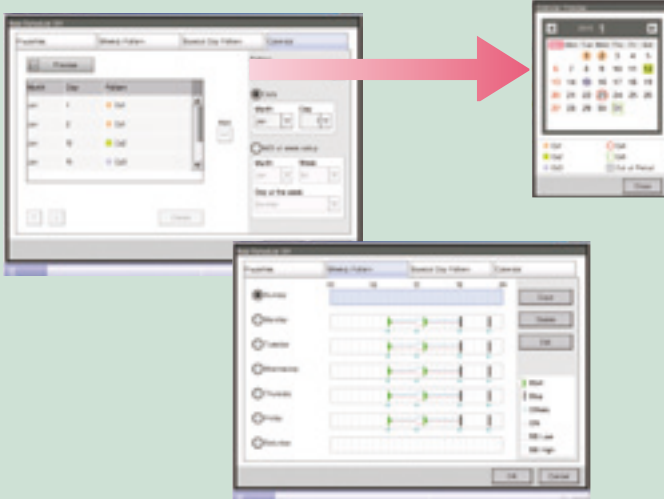

- A weekly schedule can be set for any air conditioning unit and its group.
- Administrator can also set Start/Stop, Setpoint and below conditions:
 - Pre-Cool/Heat • Setback High/Low
 - Remote Controller Restriction • Timer Extension
 - Setpoint Shift • Fan Speed • Setpoint Restriction
- Holidays and special days can be set. Monthly schedule can be easily checked on the calendar.
- An expiration date can be set for each schedule. This enables a schedule pattern to be automatically changed according to the season.

Interlock Variety

The *intelligent Touch Manager* offers interlock variety that extends beyond simply starting and stopping interlocks to automatic interlocks of connected units. This enables the system to control air conditioning equipment in performance of such operations as free cooling and time-delayed ventilation.

Example 1 Free cooling

When the outdoor temperature is lower than the predetermined temperature, the cooling operation stops, and outdoor air is directly introduced through the ventilation unit to save energy.

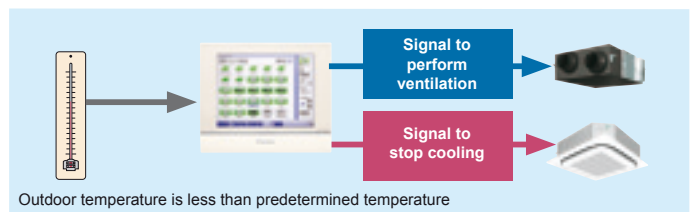

Example 2 Ventilation control

Ventilation equipment is controlled depending on the indoor CO₂ levels. Air conditioning losses attributed to unnecessary ventilation are reduced while maintaining appropriate use of indoor air and enabling greater energy efficiencies.

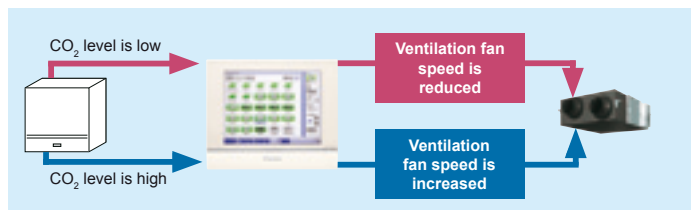

Example 3 Air conditioning interlock according to room occupancy status

Key control systems and occupancy sensors are employed to detect room occupancy status and automatically perform setback or stop operations for unoccupied rooms depending on settings.

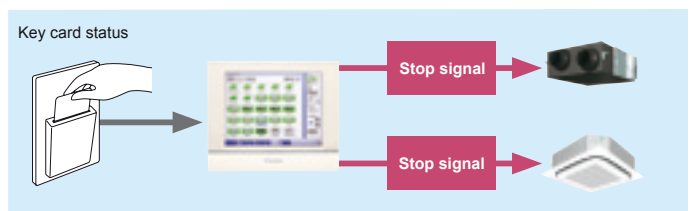

Interlock variety enables greater functionality between air conditioning equipment and peripheral equipment.

Emergency stop for localised fire protection areas

By interlocking fire alarms, the system can perform an emergency stop of air conditioning and ventilation units and execute for either all air conditioning units, or only affected fire protection areas.

Having centralised control to perform an emergency stop on localised fire protection areas offers building managers of multi-tenant buildings a choice for maximising safety of affected areas without disrupting activities of those areas that are unaffected.

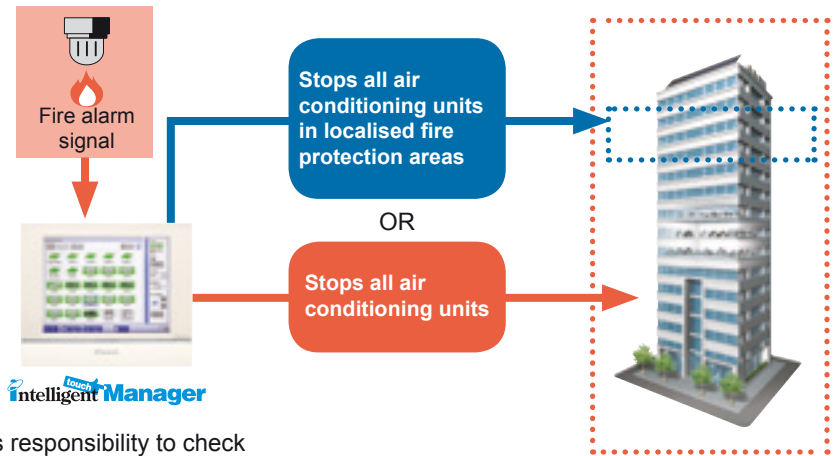

Note: It is the consulting engineer / contractor's responsibility to check and confirm this approach meets with relevant local authority regulations

Comfortable energy-efficient control

Automatic Changeover

Cooling/heating operations of each room can be automatically changed based on setpoint and room temperature.

* In the case of heat pump type VRV, cooling/heating operations can be changed at the same time for the entire VRV system.

Setback

Unoccupied rooms such as offices at night have no need for maximum air conditioning operation to maintain a suitable room environment. The setback feature scales back air conditioning in unoccupied rooms to prevent unnecessary energy consumption and provide lower electricity costs.

Timer Extension

To conserve energy when rooms are left unoccupied, the system has an automatic stop operation for air conditioning units that turns off the air conditioning after a predetermined time. This can be a true energy saver for a variety of building types including school classrooms.

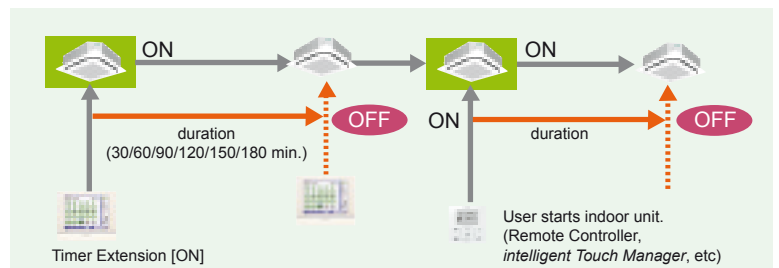

Sliding Temperature

This function is designed to change setpoint to reduce differences between the outdoor and indoor temperatures. Particularly useful at building entrances and similar locations, this function effectively prevents a "heat shock" from exposure to a sudden drop in temperature and can also enhance energy efficiencies.

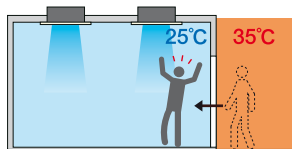

Heat shock is likely to occur when differences between indoor and outdoor temperatures are substantial.

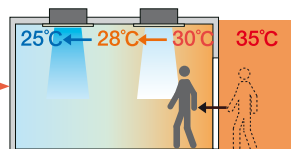

Heat shock can be prevented by providing a gradual decline in temperature that minimises the steep differences between indoor and outdoor temperatures near entrances.

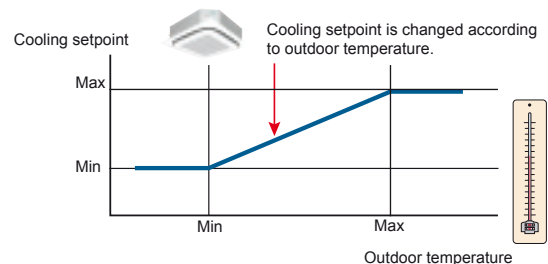

Energy management

Energy saving control assisted by Energy Navigator (Option)

Energy consumption trends of all the equipment (including air conditioning units) can be easily understood by using the Energy Navigator feature. Here users can identify air conditioning units that are suspected of overcooling or kept running in unoccupied rooms. The Energy Navigator feature will also provide support in formulation and verification of energy-saving measures to help ensure advanced energy management.

Hourly energy consumption is measured and the *intelligent Touch Manager* records data sent from the electrical meter.

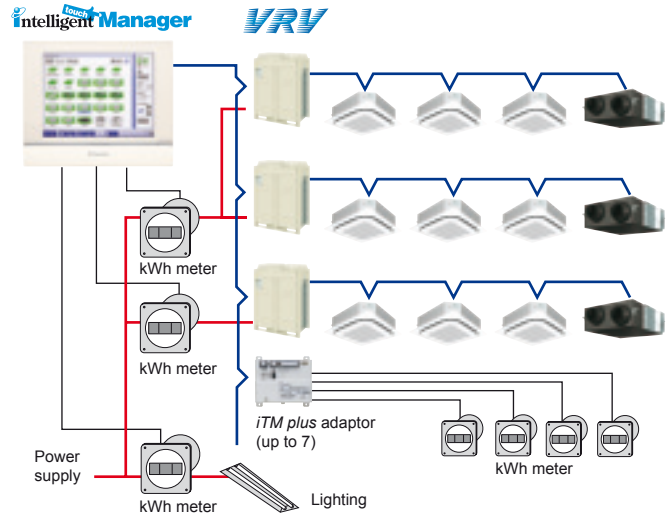

Accumulated data appears in an easy-to-understand graph.

Energy consumption data is presented on a daily and monthly basis. Also, energy targets and projected energy consumption data as well as comparison data with the previous year's actual results are presented in a user-friendly format to help ensure energy-saving control.

Daily energy consumption

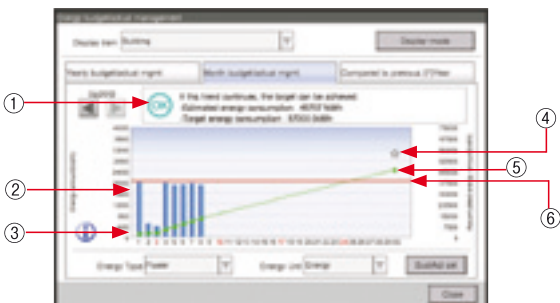

- ① Warning indication
- ② Actual daily energy consumption
- ③ Cumulate line
- ④ Current month's target
- ⑤ Prediction line
- ⑥ Daily average to achieve month's target

Monthly energy consumption

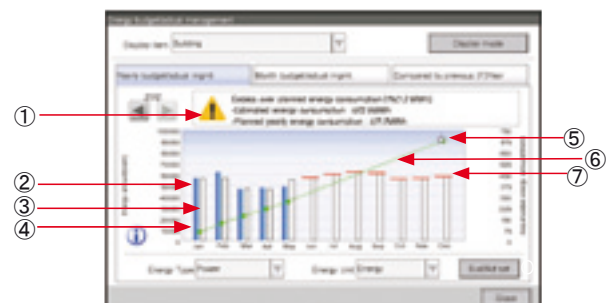

- ① Warning indication
- ② Actual monthly energy consumption
- ③ Monthly target energy consumption
- ④ Cumulate line
- ⑤ Current year's target
- ⑥ Prediction line
- ⑦ Monthly target to achieve year's target

Comparison from the previous year

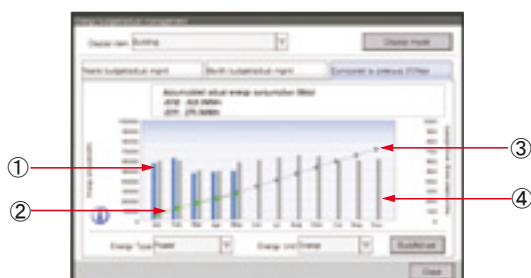

- ① Current year's energy use
- ② Current year's cumulate line
- ③ Previous year's cumulate line
- ④ Previous year's energy use

Information concerning energy management of the system can be viewed on the user's own PC via LAN.



Energy consumption is automatically evaluated for each room.

Based on the accumulated data, the *intelligent Touch Manager* automatically identifies rooms and air conditioning units that substantially deviate from operation rules established by the user for operation time and predetermined temperature settings. A benchmark showing ways to further reduce energy consumption can be displayed to alert users to even greater energy and cost efficiencies.

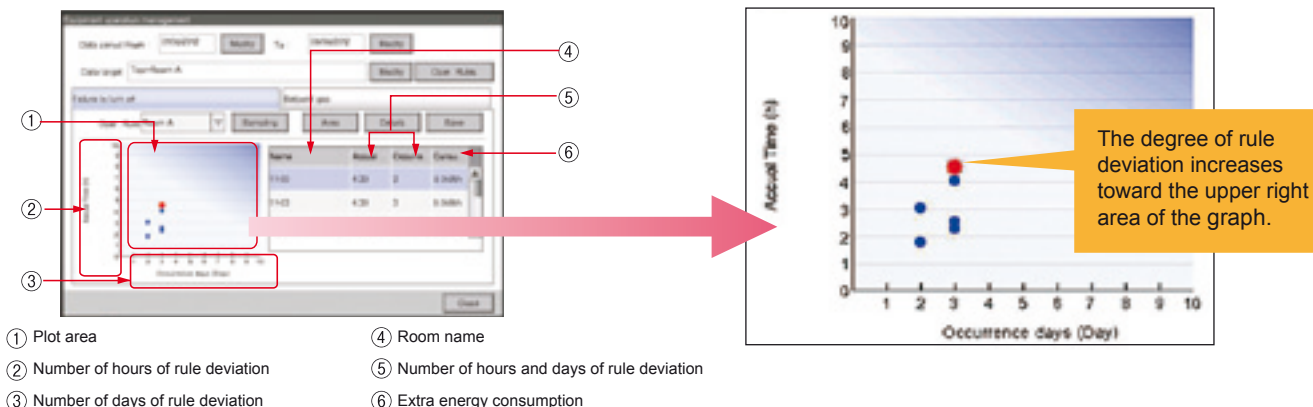

With the PPD function, power consumption can be calculated for each indoor unit. (Option)

The energy consumption is proportionally calculated for each indoor unit. The data can be used for energy management and calculation of air conditioning usage for respective tenants.

Operational information of individual indoor units are monitored, allowing for distribution of power consumption at outdoor units.

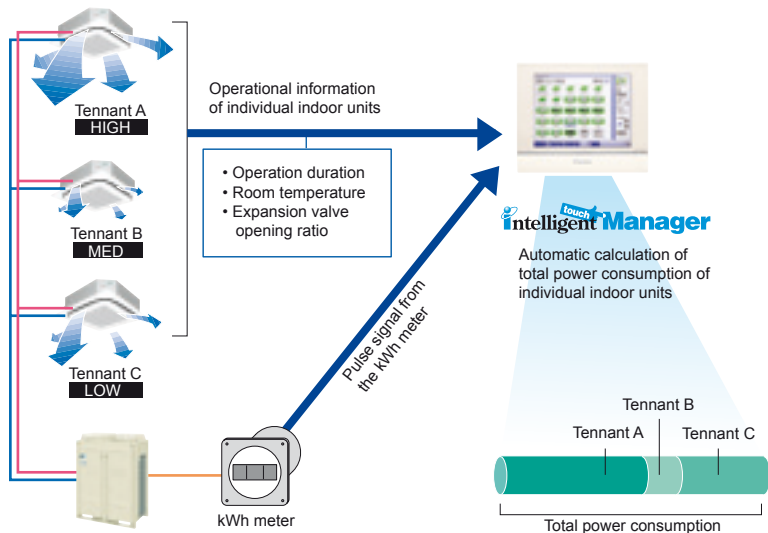

Daikin's PPD* keeps track of power distribution for each indoor unit. It performs air conditioning power consumption calculations quickly and automatically.

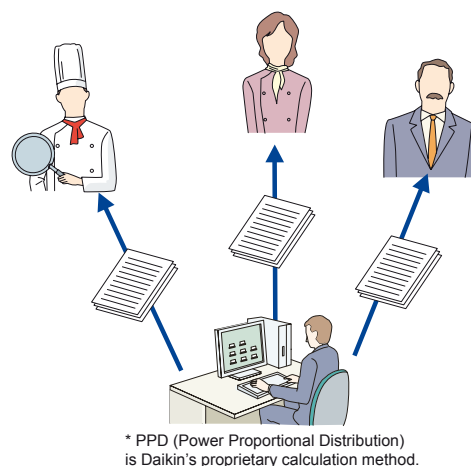

It is easy to output PPD data.

PPD data is output in CSV format to a PC or USB memory device and can be freely processed and managed.

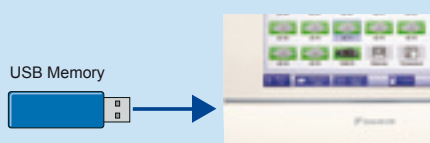

Troubleshooting

Various functions for simplifying troubleshooting

Display of maintenance contact information

Contact information of maintenance contractors (who are responsible for servicing air conditioning equipment) can be registered and displayed.

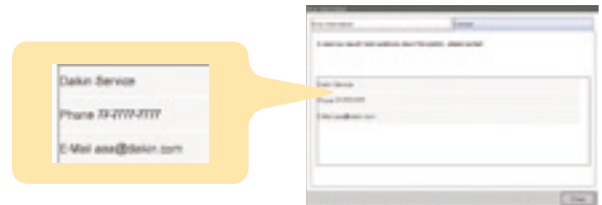

E-mail alerts for reporting malfunctions

E-mail alerts are sent to inform concerned parties of malfunctions involving equipment connected to the intelligent Touch Manager. Conveying equipment models and error codes, these e-mail alerts enable recipients to take prompt action and can be set for specific equipment.

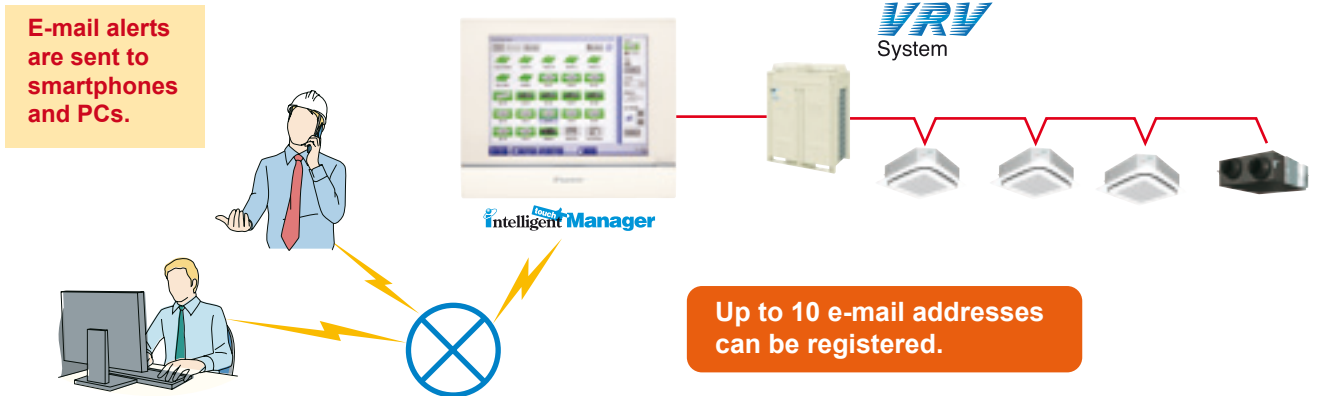

Air Conditioning Network Service System (Optional Maintenance Service)

The *intelligent Touch Manager* can be connected to Daikin's own Air Conditioning Network Service System for remote monitoring and verification of operation status for air conditioning units. By its ability to predict malfunctions, this service provides customers with additional peace of mind.

Enhanced convenience with link to the Air Conditioning Network Service System

The intelligent Touch Manager connects seamlessly to Daikin's 24-hour Air Conditioning Network Service System.

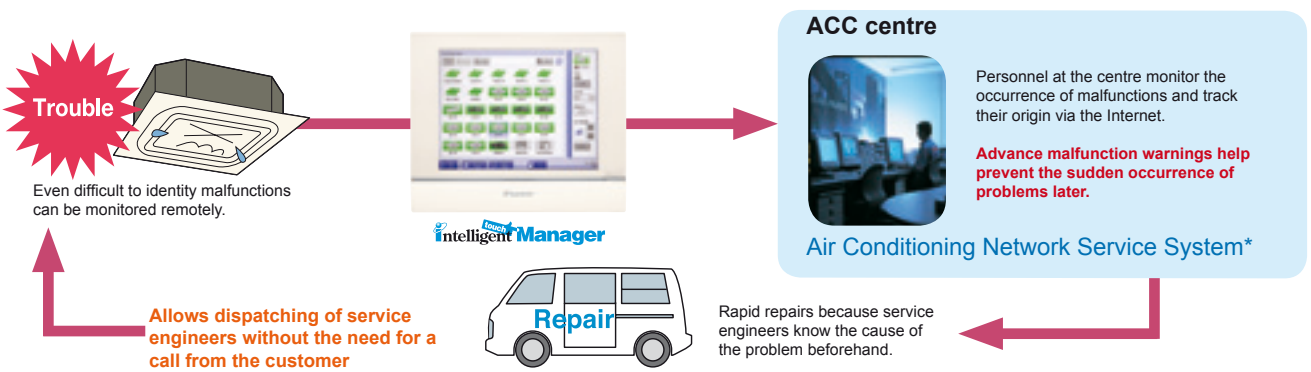

*Because of restrictions in applicable areas and release times, please consult a Daikin representative separately for details.

Scalability

A single *intelligent Touch Manager* enables centralised control of up to 512 groups of VRV indoor units.

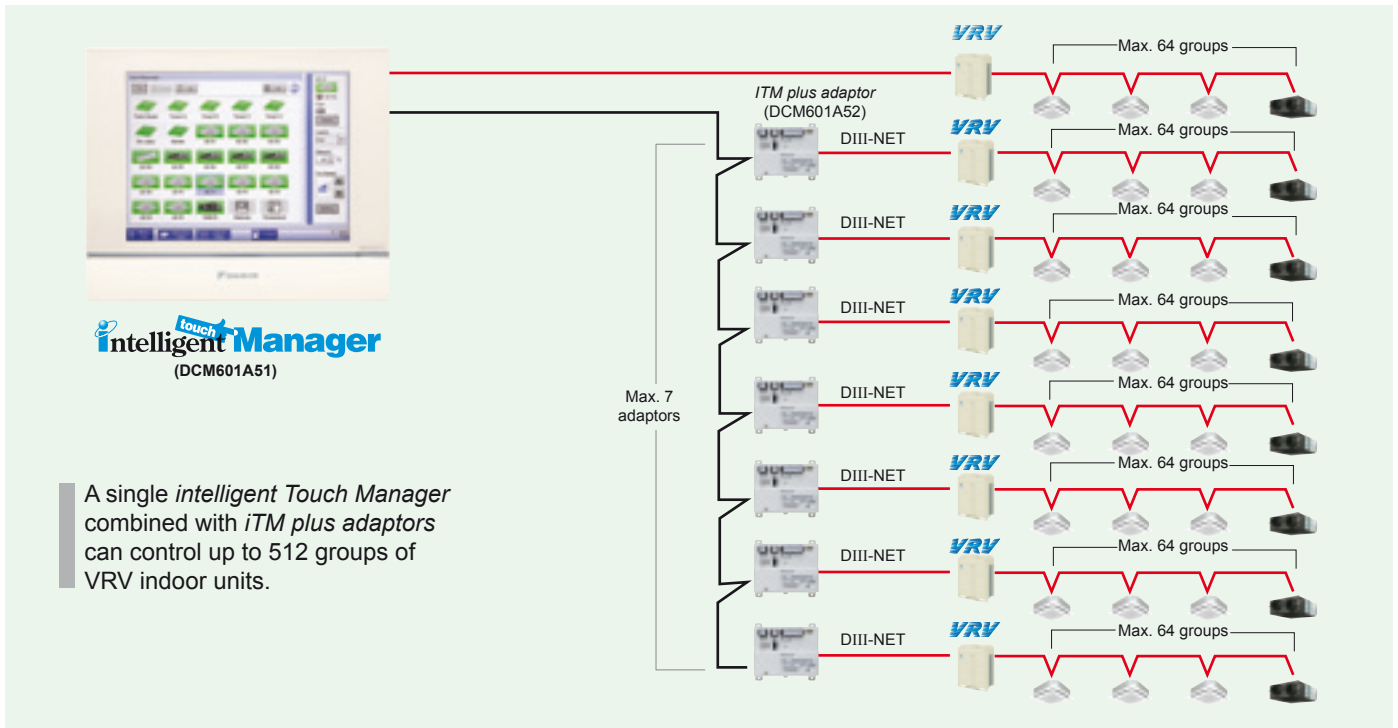

Integration of five *intelligent Touch Managers* enables centralised monitoring of up to 2,560 groups of VRV indoor units

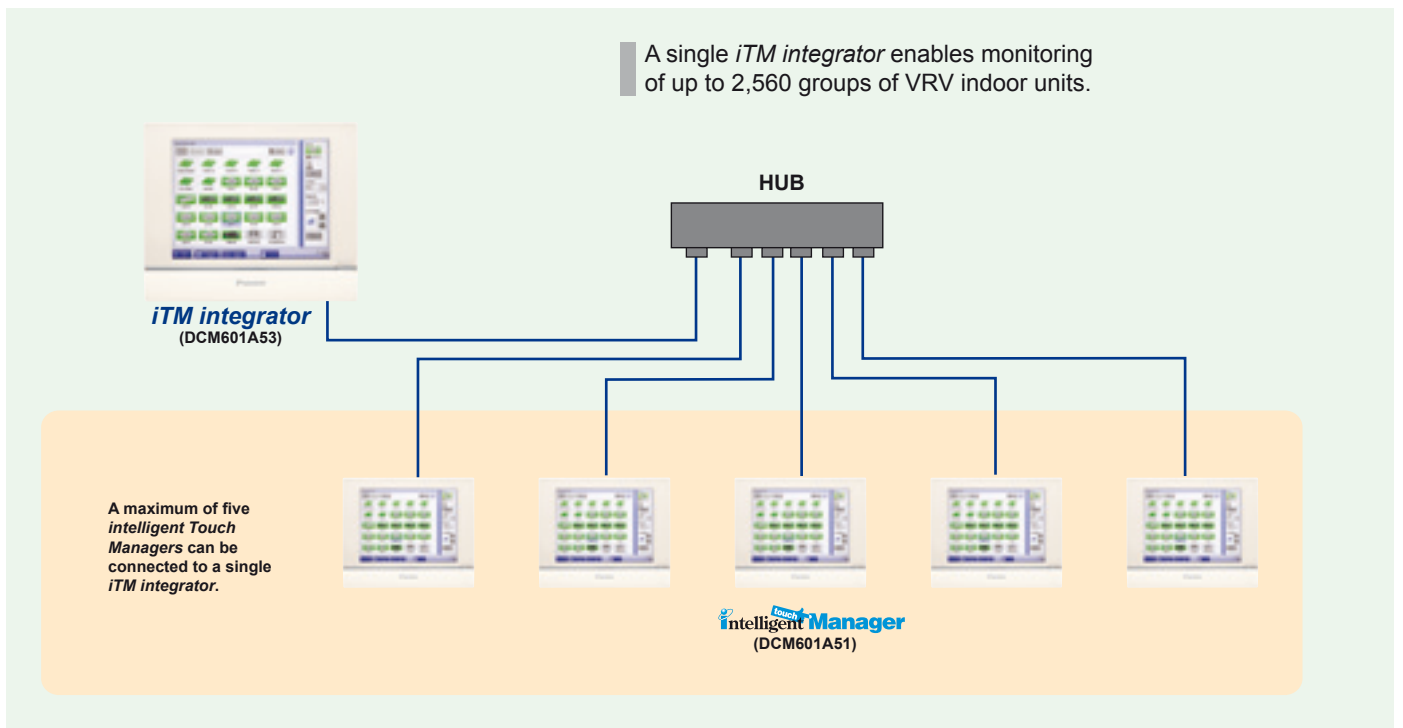

intelligent Touch Manager function

Category	Function	Remarks	
Basic functions	<i>iTM plus adaptor</i> (DCM601A52)	Maximum number of adaptors: 7	
	Management points	Maximum number of management points: 650 (Number of DIII connection management points: 512)	
	Areas	Maximum number of areas: 650 Maximum area hierarchies: 10	
	Supported languages	English, French, German, Italian, Spanish, Portuguese, Dutch, Chinese, and Japanese	
	Monitoring screens	Icon view	Icons show the operation status of equipment.
		List view	Detailed information of each management point is displayed.
Layout view		Up to 60 screens can be created.	
History	Up to 100,000 events are recorded in history including malfunctions, operations, automatic control, and system information. Operation origin is also recorded.		
Automatic control	Schedule	Number of programmes: 100 Up to 20 actions/day can be set.	
		Weekly schedule	7 days of the week + 5 special days can be set.
		Yearly calendar	Special days can be specified by date or month/week/day of the week. Special day settings can be reused every year.
	Seasonal schedule	Programmes for respective seasons can be switched by date.	
	Interlock	Number of programmes: 500 Interlock is possible for on/off, malfunction, analogue value, and operation mode switching.	
	Emergency stop	Number of programmes: 31	
	Automatic changeover	Number of changeover groups: 512	
	Temperature limit	Number of temperature limit groups: 8 Upper limit range: 32-50°C Lower limit range: 2-16°C	
	Sliding temperature	Number of sliding temperature groups: 8 Outdoor temperature range: 18-34°C Setpoint range: 16-32°C	
	Heating Mode Optimisation (HMO)	Unneeded heating is prevented.	
	Timer extension	Operation stop is selectable from 30, 60, 90, 120, 150 and 180 minutes.	
Setback	Setback setpoint can be set for two patterns. Temperature range: 1-7°C , -1--7°C (setpoint shift amount)		
Data control	Power Proportional Distribution	Hourly Power Proportional Distribution results up to 13 months are recorded. The system supports data output in CSV format.	
	Energy Navigator	Actual results of daily/monthly energy consumption are shown in graphs. Comparisons can be made with predetermined values/actual results of the previous year. Inefficient operation of VRV indoor units is automatically identified, and energy waste is calculated.	
Remote access	Web access	Web browsers can display the same type of screen as the <i>intelligent Touch Manager</i> . Up to four administrators and 60 general users can be registered. Screens and operation accessible to general users can be restricted.	
	E-mail alerts	Up to 10 e-mail addresses can be set. Addresses for sending malfunction alerts can be set by range of management points. The SMTP server authentication method is selectable from no authentication, POP before SMTP, and SMTP-AUTH.	
System	Automatic registration	Indoor units connected to DIII-NET are automatically detected, and icons for respective models are automatically registered.	
	Security	Screen lock functions are available. Access restrictions can be set for each general user.	
	Screen savers	Screen savers are selectable from three patterns.	
	Setting of contact information	Contact information for servicing can be registered.	
Air Conditioning Network Service	Air Conditioning Network Service System	A service agreement needs to be concluded.	
	Energy Saving Air Conditioning Network Service System	A service agreement needs to be concluded.	

■ iTM integrator function

Category	Function	Remarks
Basic functions	<i>intelligent Touch Manager</i> (DCM601A51)	Maximum number of units: 5
	Management points	Maximum number of management points: 3,250 (number of DIII connection management points: 2,560)
	Areas	Maximum number of areas: 3,250 Maximum area hierarchies: 10
	Supported languages	English, French, German, Italian, Spanish, Portuguese, Dutch, Chinese, and Japanese

■ Types of management points and target equipment/interface

Management point	Supported equipment	Number of management points
Indoor	DIII-compatible indoor units	Maximum: 512 *1
	Interface adaptor for SkyAir (DTA102A52)	
	Interface adaptor for residential indoor unit (KRP928BB2S)	
	Central control adaptor kit (DTA107A55)	
Outdoor	VRV outdoor units	Maximum: 80
Ventilator	Heat Reclaim Ventilator	Maximum: 512 *1
D3 Chiller	DIII-compatible air-cooled chillers (UWA/Y)/water-cooled chillers (ZUW)	Maximum: 320 *2
Di	Di port of <i>intelligent Touch Manager</i>	Maximum: 32 *3
	Di port of <i>iTM plus adaptor</i>	
D3 Di	DIII Di Unit (DEC101A51)	Maximum: 512 *1
External Di	Wago Di	Maximum: 512 *4
D3 Dio	DIII Dio Unit (DEC102A51)	Maximum: 512 *1
	General-purpose adaptor (DTA103A51)	
External Dio	Wago Di, Do	Maximum: 512 *4
Pi	Pi port of <i>intelligent Touch Manager</i>	Maximum: 32 *3
	Pi port of <i>iTM plus adaptor</i>	
Internal Pi	Energy consumption of VRV outdoor units	Maximum: 80
External Ai	Wago Ai	Maximum: 512 *4
Internal Ai	Room temperature, setpoint D3 Chiller outlet/inlet water temperatures	Maximum: 512 *4

*1: Total of DIII connection equipment (Indoor, Ventilator, D3 Chiller, D3 Di, D3 Dio)

*2: Maximum number of management points for D3 Chiller only

*3: Total of Di/Pi management points

*4: Total of External Di, External Do, External Ai, and Internal Ai

■ DAIKIN supplied equipment

Model	Item
DCM601A51	<i>intelligent Touch Manager</i>
DCM601A52	<i>iTM plus adaptor</i> (Option)
DCM601A53	<i>iTM integrator</i> (Option)
DCM002A51	iTM power proportional distribution software (Option)
DCM008A51	iTM energy navigator software (Option)

■ Locally supplied equipment

Item	Specification
USB memory	USB 2.0 Up to 32GB memory can use
PC for Web access	Windows XP Professional SP3 (32bit) Windows VISTA Business SP2 (32bit) Windows 7 Professional SP1 (32bit, 64bit) Monitor: 1024x768 or more Web browser: Internet Explorer 8, 9 Firefox 10.0 Flash Player Ver11.1
WAGO I/O system	Modbus communication unit: 750-315/000-002/K190-6442 DC24V power supply unit: 787-712 DC24V power supply module: 750-613 Connector: 750-960 Terminator module: 750-600 Di module: 750-400, 750-432 Do module: 750-513/000-001 Ai module: 750-454, 750-479 Thermistor module: 750-461/020-000

Intelligent Touch Manager

Port	Number	Use
DIII	1ch	DIII-NET (Up to 64 groups)
LAN	1ch	Web Access (100BASE-TX)
RS485	1ch	External I/O module (Di, Dio, Ai)
Di(Pi)	4ch	Emergency stop input (Di1) Pulse input,contact signal input
plus ADP IF	1ch	<i>itm plus adaptor</i> (Up to 7 adaptors)
Internal modem (option)	1ch	Air Conditioning Network Service System

POWER SUPPLY: DCM601A51 AC100-240V(±10%)(50/60Hz)
 INPUT: 23W
 MASS: 2.4kg
 FUSE AMP: 3.15A
 Operating temperature limit: -0°C - +40°C
 Operating humidity limit: MAX.15 - 85%
 Storage temperature range: -15°C - +60°C
 Installation direction: Vertical direction only

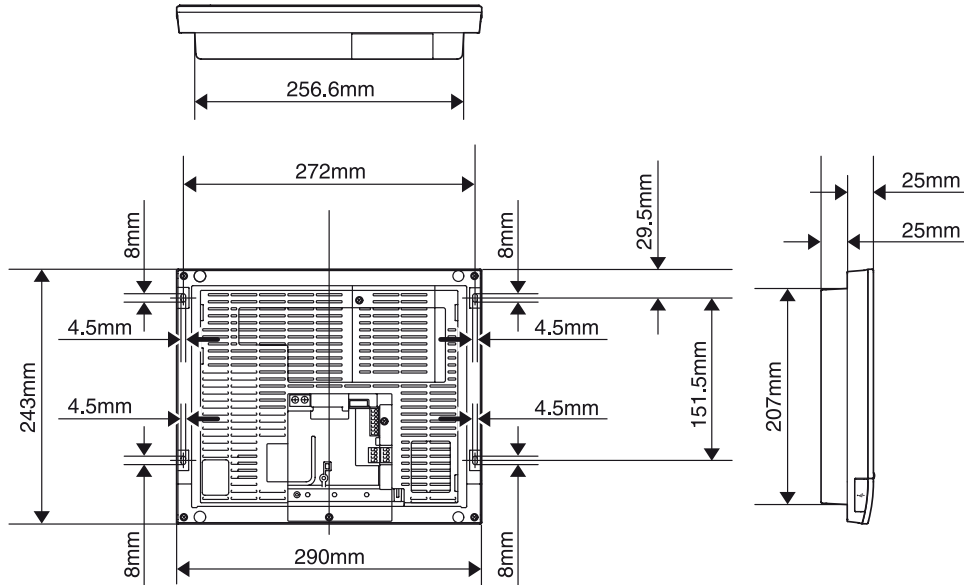

itm plus adaptor (DCM601A52) Input/Output port

Port	Number	Use
plus ADP IF	1ch	<i>itm plus adaptor</i> (Up to 7 adaptors)
DIII	1ch	DIII-NET (Up to 64 groups)
Di(Pi)	4ch	Pulse input, contact signal input

POWER SUPPLY: DCM601A52 AC100V-240V(±10%)(50/60Hz)
 INPUT: 6W
 MASS: 0.5kg
 FUSE AMP: 3.15A
 Operating temperature limit: -10°C - +50°C
 Operating humidity limit: MAX.15 - 85%
 Storage temperature range: -15°C - +60°C
 Installation direction: Vertical direction only

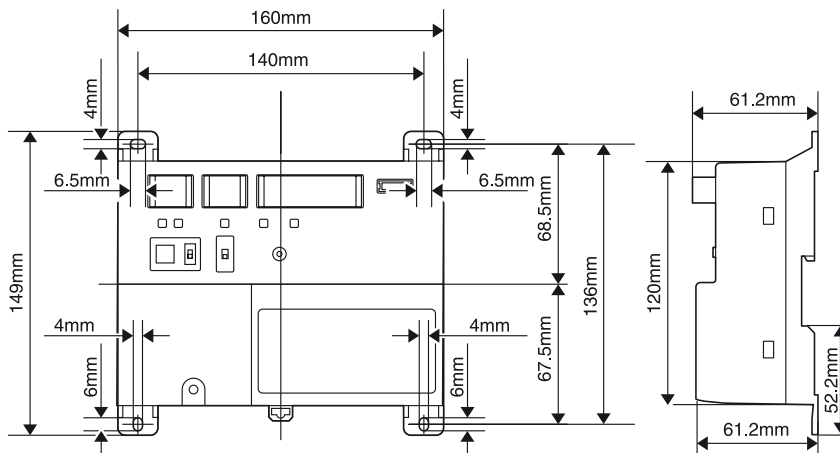

Daikin offers a variety of other air conditioning control systems.

Convenient controllers that offer more freedom to administrators



DCS601C51

Intelligent touch Controller

Ease of use and expanded control functions

The user-friendly controller features colours, multilingual function, and icons in the display for ease of understanding. A wide variety of control methods can be accommodated, permitting administrators to monitor and operate the system even when they are away from the controller.

Connect VRV to your BMS via BACnet® or LonWorks®



Compatible with BACnet® and LonWorks®, the two leading open network communication protocols, Daikin offers interfaces that provide a seamless connection between VRV and your BMS.

Dedicated interfaces make Daikin air conditioners freely compatible with open networks.

BACnet®

Seamless connection between VRV and BACnet® open network protocol.



DMS502B51
(Interface for use in BACnet®)

LonWorks®

Facilitating the network integration of VRV and LonWorks®



DMS504B51
(Interface for use in LonWorks®)

Notes:

1. BACnet® is a registered trademark of American Society of Heating, Refrigerating and Air-Conditioning Engineers (ASHRAE).
2. LonWorks® is a trademark of Echelon Corporation registered in the United States and other countries.

Using *intelligent Touch Manager*

1. A Daikin-trained engineer must perform installation of the *intelligent Touch Manager*.
2. The clock of the *intelligent Touch Manager* should be adjusted once a month.
3. Daikin's unique PPD system calculates the energy consumption of each indoor unit based on its operation data output. Note that PPD is not a "meter" adapted to the methods of measuring electrical power consumption in each country. Tenant billing systems differ by country according to each country's respective legal system.



JMI-0107

Organization:
DAIKIN INDUSTRIES, LTD.
AIR CONDITIONING MANUFACTURING DIVISION

Scope of Registration:
THE DESIGN/DEVELOPMENT AND MANUFACTURE OF
COMMERCIAL AIR CONDITIONING, HEATING, COOLING,
REFRIGERATING EQUIPMENT, HEATING EQUIPMENT, HEAT
RECLAIM VENTILATION, AIR CLEANING EQUIPMENT,
COMPRESSORS AND VALVES.



All of the Daikin Group's business
facilities and subsidiaries in Japan
are certified under the ISO 14001
international standard for
environment management.

Dealer

DAIKIN INDUSTRIES, LTD.

Head Office:
Umeda Center Bldg., 2-4-12, Nakazaki-Nishi,
Kita-ku, Osaka, 530-8323 Japan

Tokyo Office:
JR Shinagawa East Bldg., 2-18-1, Konan,
Minato-ku, Tokyo, 108-0075 Japan
http://www.daikin.com/global_ac/

© All rights reserved
05/12 AD